

## Cycling Shorts - Kids

Key	Description / Size	SB	MB	LB	XLB	+/-
K	Waist Relax	9 ½	10	10 ½	11	¼
K1	Waist Stretch	10 ½	11	11 ½	12	¼
L	Front Rise	9 ½	9 ¾	10	10 ¼	½
M	Back Rise	11	11 ½	12	12 ½	½
N	Outside Leg	13	13 ½	14	14 ½	½
P1	Inside Leg Seam	10	11	12	13	½
O	Leg Opening	13	13 ¼	13 ½	13 ¾	¼

Ref:

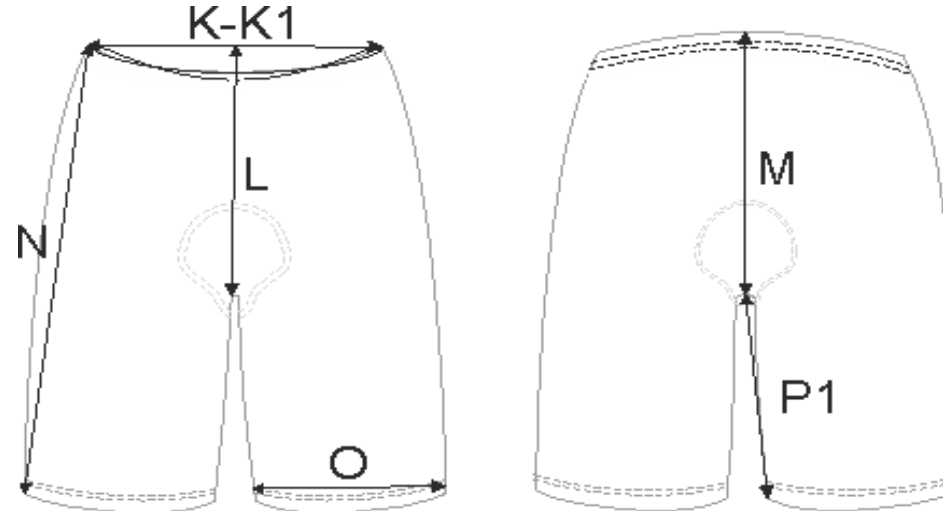

## Cycling Shorts - Mens

Key	Description / Size	XS	S	M	L	XL	2XL	3XL	4 XL	+/-
K	Waist Relax	10 ½	11 ½	12 ½	13 ½	14 ½	15 ½	16 ½	17 ½	¼
K1	Waist Stretch	11 ½	12 ½	13 ½	14 ½	15 ½	16 ½	17 ½	18 ½	¼
L	Front Rise	8 ½	9	9 ½	10	10 ½	11	11 ½	12	½
M	Back Rise	12 ½	13 ½	14 ½	15 ½	16 ½	17	17 ½	18	½
N	Outside Leg	13	14 ½	16	17 ½	19	20 ½	22	23 ½	½
P1	Inside Leg Seam	17	18	19	20	21	22	23	24	½
O	Leg Opening	14	14 ½	15	15 ½	16	16 ½	17	17 ½	¼

Ref: 02CSO002M

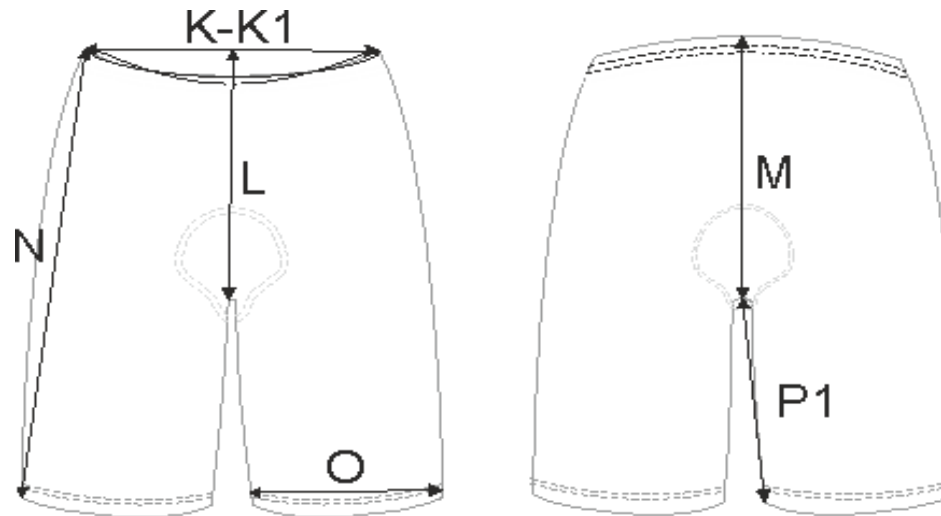

## Cycling Shorts - Ladies Fit

Key	Description / Size	8	10	12	14	16	18	20	22	+/-
K	Waist Relax	10	11	12	13	14	15	16	17	¼
K1	Waist Stretch	11	12	13	14	15	16	17	18	¼
L	Front Rise	8 ½	9	9 ½	10	10 ½	11	11 ½	12	½
M	Back Rise	14½	15	15½	16	16 ½	17	17 ½	18	½
N	Outside Leg	16	16 ¾	17 ½	18 ¼	19	19 ¾	20 ½	21 ¼	½
P1	Inside Leg Seam	18	18 ½	19	19 ½	20	20 ½	21	21 ½	½
O	Leg Opening	14	14 ½	15	15 ½	16	16 ½	17	17 ½	¼

Ref: 02CS002L

